

# TS/ WB Roller Manuals



[www.true-surface.com](http://www.true-surface.com)

# True-Surface® Vibratory Greens Rollers

WB & TS Model Rollers to fit Toro 3000, 3050, 3100, GM & GM300

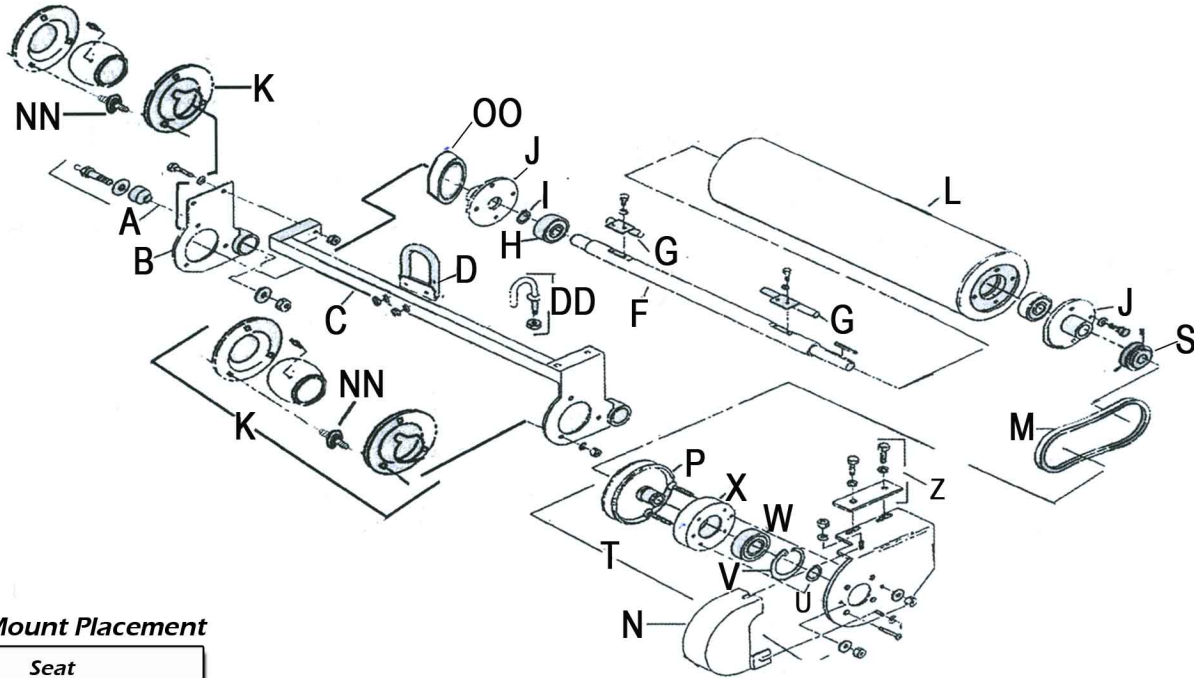

## Motor Mount Placement

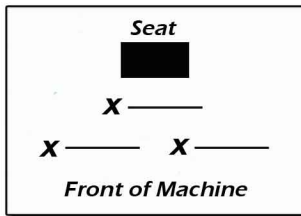

Parts are the same on all units unless otherwise noted.  
 Units are as seated on the operator's seat.  
 Parts include all necessary hardware.

US Patent No. 5,261,231  
 Foreign Patents Passed & Pending

# True-Surface® Vibratory Greens Rollers

## WB & TS Model Rollers to fit Toro 3000, 3050, 3100, GM & GM300

<b>Letter</b>	<b>Description</b>	<b>All Units</b>
A	Ball Stud Assembly	30A-32-1
B	Endplate Assembly	30A-10-1
C	Frame Assembly	30A-11-1
DD	Anti-Rotation Hook Assembly	30A-12-1AR
D	Lift Hook Assembly	30A-13-1LH
E	Motor Mount Shell	30A-39-1SHELL
F	Shaft Only	30A-09-18
G	Eccentric Weight 3 1/4"	99P-09-314
G	Eccentric Weight 5"	99P-09-500
H	Shaft Bearing	37P-1023
I	Shaft Snap Ring	37P-1014
J	Hub Assembly Drive End	30A-09-001
J	Hub Assembly Non-Drive End	30A-09-002N
K	Flanged Bearing Drive End - WB Model *Includes 3 each of Item NN	30A-1016-2
K	Flanged Bearing Non Drive End - WB Model *Includes 3 each of Item NN	30A-1016-3
K	Flanged Bearing - TS Model	30A-1016-4
L	Roller Assembly	37P-09-1
M	19" Belt	37P-1021
N	Belt Guard Assembly	37P-14-1
P	5" Pulley to fit all Toro	37P-PT003-32
S	Shaft Pulley	37P-1024
T	Quick Fit Motor Mount Assembly	30A-39-1
Includes the Following Parts:		
	<i>E Motor Mount Shell</i>	<i>30A-39-1 SHELL</i>
	<i>M 19" Belt</i>	<i>37P-1021</i>
	<i>P 5" Pulley to fit all Toro</i>	<i>37P-PT003-32</i>
	<i>U Pulley Snap Ring</i>	<i>37P-1029</i>
	<i>V Bearing Snap Ring</i>	<i>37P-1127</i>
	<i>X Bearing Housing</i>	<i>30M-T-150</i>
	<i>Z Motor Mount Cover Plate</i>	<i>37P-50-1</i>
NN	Rubber Shock Mount Assembly	30A-RSM
OO	Hub Spacer	37P-3173
W	Bearing for 5" Pulley	37P-1032

# True-Surface® Vibratory Greens Rollers

## WB & TS Model Rollers to fit Toro 3200A

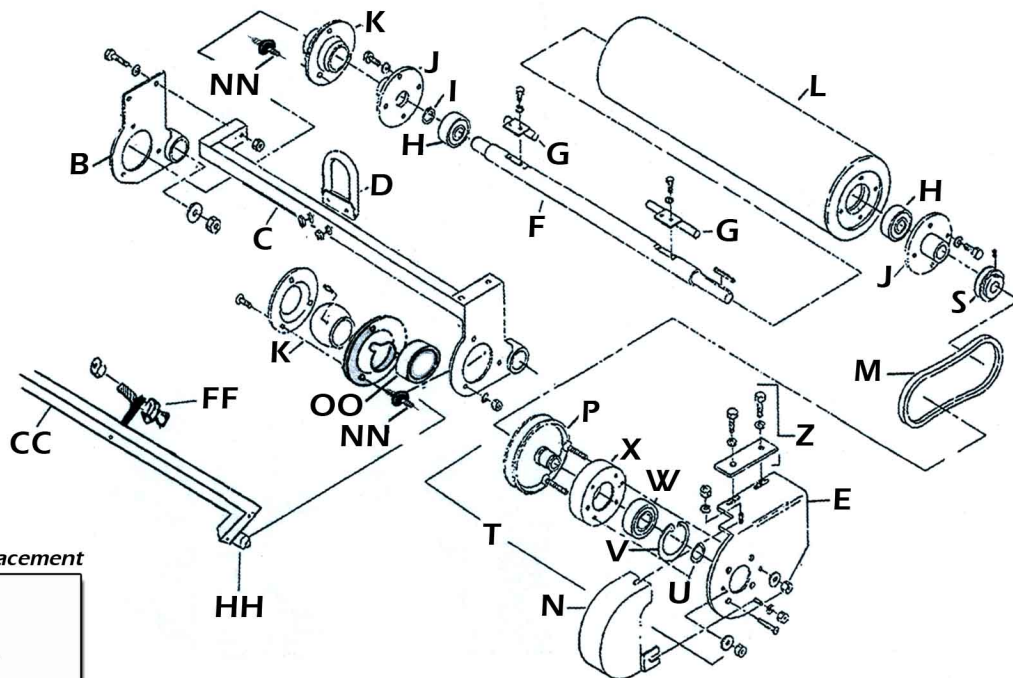

### Motor Mount Placement

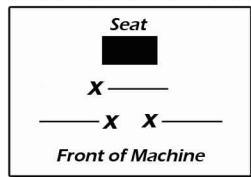

US Patent No. 5,261,231  
Foreign Patents Passed & Pending

# True-Surface® Vibratory Greens Rollers

## WB & TS Model Rollers to fit Toro 3200A

Letter	Description	Left Unit	Right Unit	Center Unit
B	Endplate Assembly	37P-10-1		
C	Frame Assembly	30A-62-1	30A-61-1	30A-63-1
D	Lift Hook Assembly	37P-13-1LH		
E	Motor Mount Shell Only	30A-38-1 SHELL	30A-34-1 SHELL	30A-38-1 SHELL
F	Shaft Only	30A-09-18		
G	Eccentric Weight 3 1/4"	99P-09-314		
G	Eccentric Weight 5"	99P-09-500		
H	Shaft Bearing	37P-1023		
I	Shaft Snap Ring	37P-1014		
J	Hub Assembly Drive End	30A-09-001		
J	Hub Assembly Non-Drive End	30A-09-002N		
K	Flanged Bearing Drive End - WB Model *Includes 3 each of Item NN	30A-1016-2		
K	Flanged Bearing Non Drive End - WB Model *Includes 3 each of Item NN	30A-1016-3		
K	Flanged Bearing - TS Model	37P-1016-4		
L	Roller Tube	30A-09-16		
M	19" Belt	37p-1021		
N	Belt Guard Assembly	37P-14-1	37P-15-1	37P-14-1
P	5" Pulley to fit all Toro	37P-PT003-32		
S	Shaft Pulley	37P-1024		
T	Quick Fit Motor Mount Assembly			
	Includes:			
E	Motor Mount Shell	30A-31-1SHELL		
M	Belt	37P-1021		
P	Pulley	37P-PT003-32		
U	Pulley Snap Ring	37P-1029		
V	Bearing Snap Ring	37P-1127		
W	Pulley Bearing	37P-1032		
X	Bearing Housing	30M-T150		
Z	Motor Mount Plate Corner	37P-50-1		
CC	Pull Frame Assembly	30A-33-2A	30A-33-3A	30A-33-1A
FF	Pull Frame Ball Stud	37P-1115		
HH	Pull Frame Bushing	37P-1116		
NN	Rubber Shock Mount Assembly	30A-RSM		
OO	Hub Spacer	30M-3173		

# True-Surface® Vibratory Greens Rollers

## WB & TS Model Rollers to fit Toro 3200B

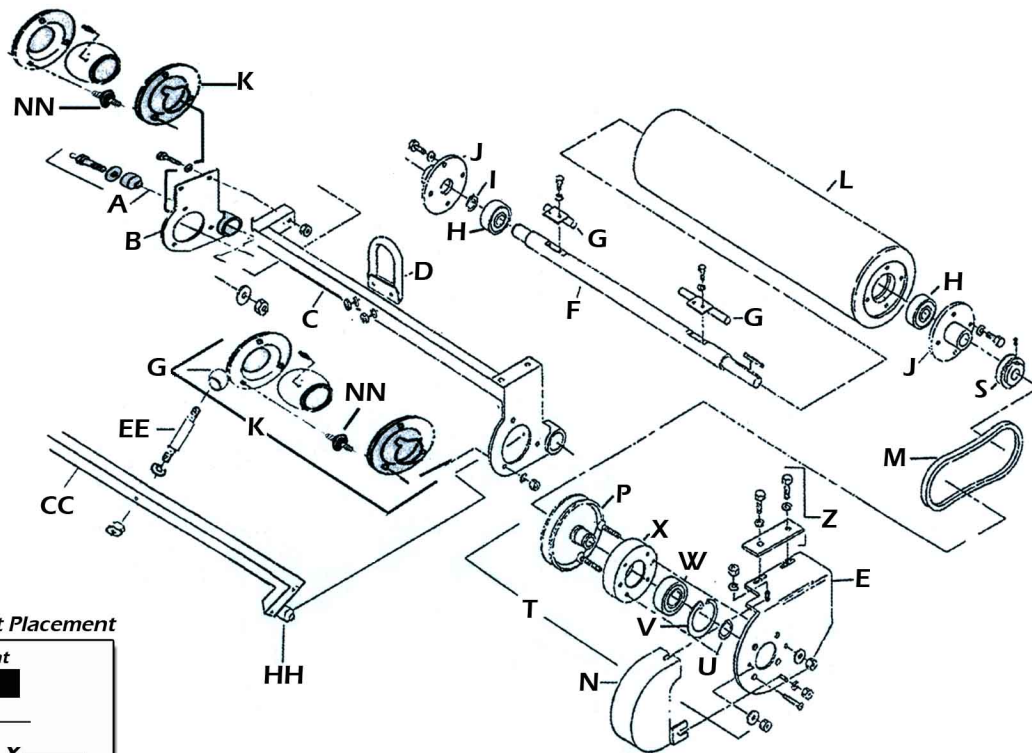

### Motor Mount Placement

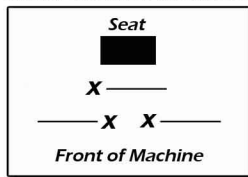

US Patent No. 5,261,231  
Foreign Patents Passed & Pending

# True-Surface® Vibratory Greens Rollers

## WB & TS Model Rollers to fit Toro 3200B

Letter	Description	Left Unit	Right Unit	Center Unit
B	Endplate Assembly	37P-10-1		
C	Frame Assembly	30A-62-1	30A-61-1	30A-63-1
D	Lift Hook Assembly	37P-13-1LH		
E	Motor Mount Shell Only	30A-39-1 SHELL	30A-34-1 SHELL	30A-39-1 SHELL
F	Shaft Only	30A-09-18		
G	Eccentric Weight 3 1/4"	99P-09-314		
G	Eccentric Weight 5"	99P-09-500		
H	Shaft Bearing	37P-1023		
I	Shaft Snap Ring	37P-1014		
J	Hub Assembly Drive End	37P-09-001		
J	Hub Assembly Non Drive End	37P-09-002		
K	Flanged Bearing Drive End - WB Model *Includes 3 each of Item NN	30A-1016-2		
K	Flanged Bearing Non Drive End - WB Model *Includes 3 each of Item NN	30A-1016-3		
K	Flanged Bearing - TS Model	37P-1016-4		
L	Roller Tube	30A-09-16		
M	19" Belt	37P-1021		
N	Belt Guard Assembly	37P-14-1	37P-15-1	37P-14-1
P	5" Pulley to fit all Toro	37P-PT003-32		
S	Shaft Pulley	37P-1024		
T	Quick fit Motor Mount Assembly			
	Includes:			
E	Motor Mount Shell	30A-31-1SHELL		
P	Pulley	37P-PT003-32		
U	Pulley Snap Ring	37P-1029		
V	Bearing Snap Ring	37P-1127		
W	Pulley Bearing	37P-1032		
X	Bearing Housing	30M-T150		
Z	Motor Mount Plate Corner	37P-50-1		
CC	Pull Frame Assembly	37P-33-2A	37P-33-3A	37P-33-1A
FF	Pull Frame Ball Stud	37P-3200C		
HH	Pull Frame Bushing	37P-1116		
NN	Rubber Shock Mount Assembly	37P-RSM		
OO	Hub Spacer	30M-3173		

# True-Surface® Vibratory Greens Rollers

## WB & TS Model Rollers to fit Jacobsen Greensking III & IV

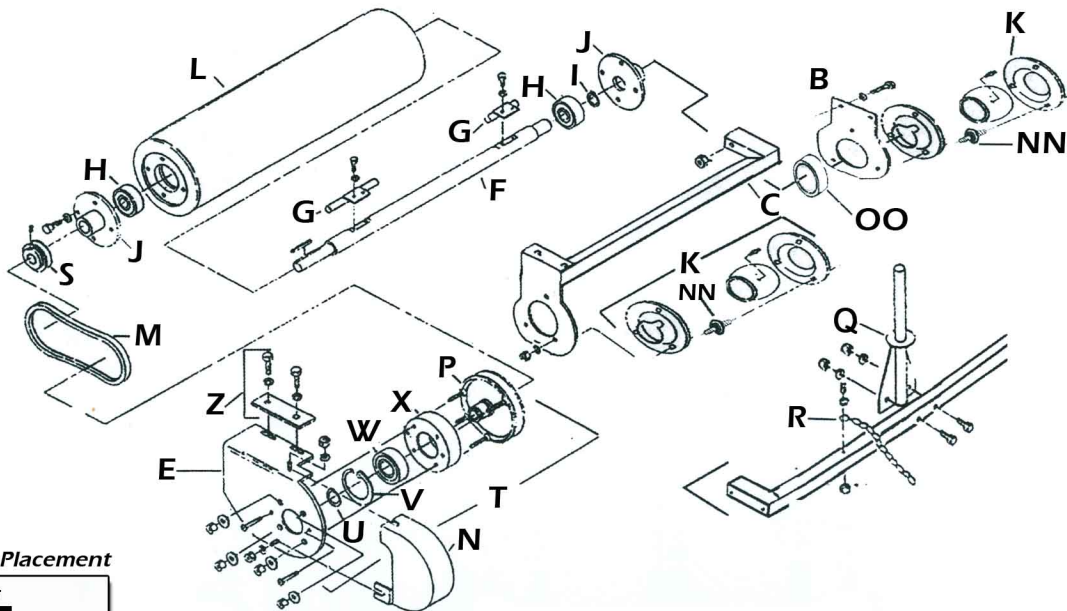

### Motor Mount Placement

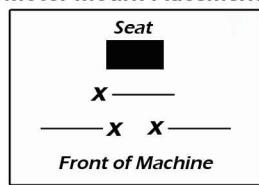

Parts are the same on all units unless otherwise noted.  
 Units are as seated on the operator's seat.  
 Parts include all necessary hardware.

US Patent No. 5,261,231  
 Foreign Patents Passed & Pending



# True-Surface® Vibratory Greens Rollers

## WB & TS Model Rollers to fit Jacobsen 3 & 4

Letter	Description	Left Unit	Right Unit	Center Unit
B	Endplate Assembly	37P-18-1		
C	Frame Assembly	30A-22-1	30A-23-1	30A-24-1
E	Motor Mount Shell	30A-31-1 SHELL	30A-38-1 SHELL	30A-38-1 SHELL
F	Shaft Assembly	30A-09-19		
G	Eccentric Weight 3 1/4"	30A-09-314		
G	Eccentric Weight 5"	30A-09-500		
H	Shaft Bearing	37P-1023		
I	Shaft Snap Ring	37P-1014		
J	Hub Assembly Drive End	30A-09-001		
J	Hub Assembly Non-Drive End	30A-09-002N		
K	Flanged Bearing Drive End - WB Model	30A-1016-2	*Includes 3 each of Item NN	
K	Flanged Bearing Non Drive End - WB Model	30A-1016-3	*Includes 3 each of Item NN	
K	Flanged Bearing - TS Model	30A-1016-4		
L	Roller Assembly	37P-09-1		
M	Belt	37P-1021		
N	Belt Guard Assembly	37P-14-1	37P-15-1	37P-15-1
P	Pulley	37P-PJ003		
Q	Lift Pin Assembly	37P-16-1		
R	Chain	30P-J11B		
S	Shaft Pulley	37P-1024		
T	Quick Fit Motor Mount	37P-31-1	37P-38-1	37P-38-1
	Includes:			
E	Motor Mount Shell	30A-31-1 SHELL	30A-38-1 SHELL	30A-38-1 SHELL
M	Belt	37P-1021		
P	Pulley	37P-PJ003		
U	Pulley Snap Ring	37P-1029		
V	Bearing Snap Ring	37P-1127		
W	Pulley Bearing	37P-1032		
X	Bearing Housing	30M-T150		
Z	Motor Mount Plate Corner	37P-50-1		
NN	Rubber Shock Mount (WB Only)	30A-RSM		
OO	Hub Spacer	37P-3173		

# True-Surface® Vibratory Greens Rollers

## WB & TS Model Rollers to fit Jacobsen Greensking V

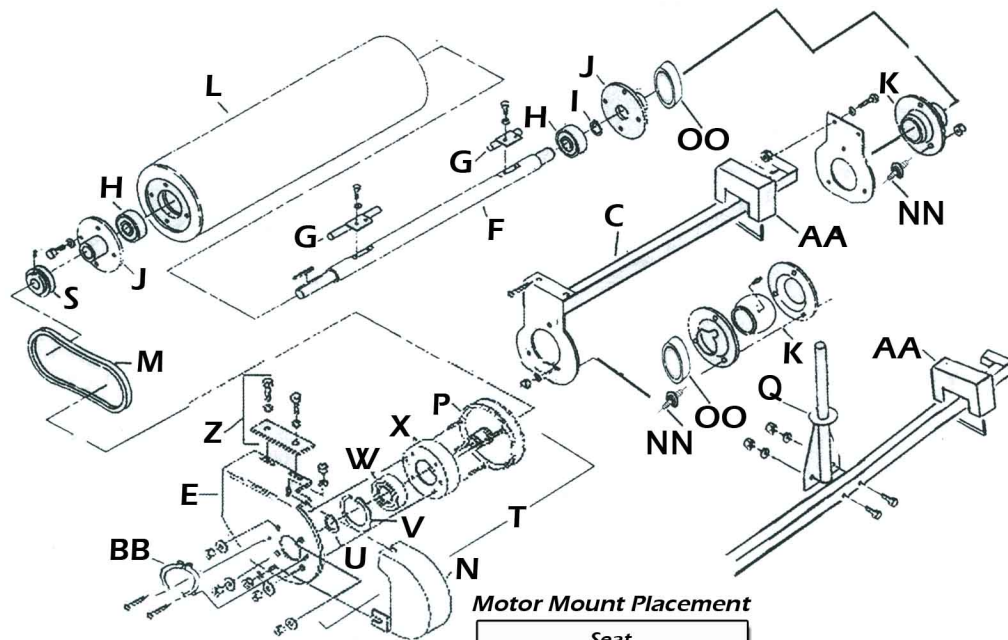

**Motor Mount Placement**

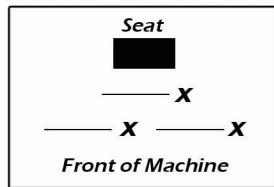

US Patent No. 5,261,231  
Foreign Patents Passed & Pending

# True-Surface® Vibratory Greens Rollers

## WB & TS Model Rollers to fit Jacobsen 5

Letter	Description	All Units
B	Endplate Assembly	37P-16-1
C	Frame Assembly	30A-22-1
E	Motor Mount Shell	30A-40-1SHELL
F	Shaft Assembly	30A-09-19
G	Eccentric Weight 3 1/4"	30A-09-314
G	Eccentric Weight 5"	30A-09-500
H	Shaft Bearing	37P-1023
I	Shaft Snap Ring	37P-1014
J	Hub Assembly Drive End	30A-09-001
J	Hub Assembly Non-Drive End	30A-09-002N
K	Flanged Bearing Drive End - WB Model *Includes 3 each of Item NN	30A-1016-2
K	Flanged Bearing Non Drive End - WB Model *Includes 3 each of Item NN	30A-1016-3
K	Flanged Bearing - TS Model	30A-1016-4
L	Roller Tube	37P-09-16
M	19" Belt	37P-1021
N	Belt Guard Assembly	37P-15-1
P	5" Pulley	37P-PJV-003
Q	Lift Pin Assembly	37P-16-1
S	2" Shaft Pulley	37P-1024
T	Quick Fit Motor Mount	37P-40-1
	Includes:	
E	Motor Mount Shell	30A-40-1SHELL
M	19" Belt	37P-1021
P	5" Pulley	37P-PJV-003
U	Pulley Snap Ring	37P-1029
V	Bearing Snap Ring	37P-1127
W	Pulley Bearing	37P-1032
X	Bearing Housing	30M-T150
Z	Motor Mount Plate Corner	37P-50-1
BB	Motor Mount Lock kit	30P-1165
AA	Counterweight Assemty	30A-64-1
NN	Rubber Shock Mount Assembly	30A-RSM
OO	Hub Spacer	37P-3173

# True-Surface® Vibratory Greens Rollers

## WB & TS Model Rollers to fit John Deere 2243

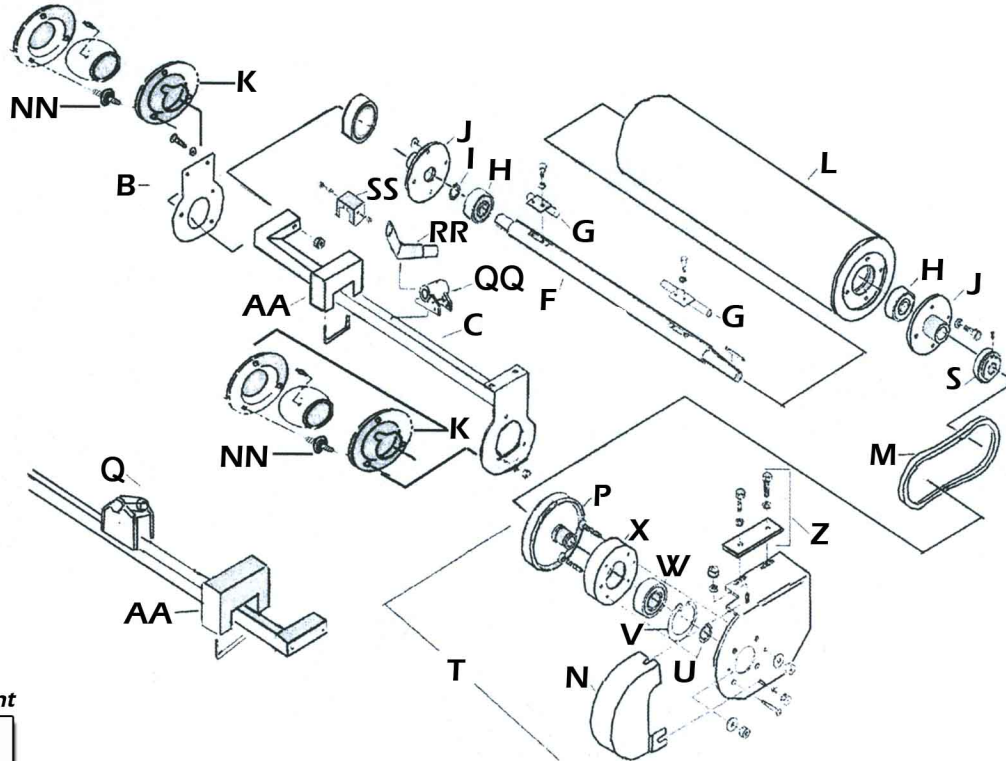

### Motor Mount Placement

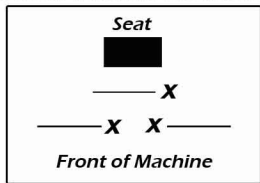

Parts are the same on all units unless otherwise noted.  
 Units are as seated on the operator's seat.  
 Parts include all necessary hardware.

US Patent No. 5,261,231  
 Foreign Patents Passed & Pending

# True-Surface® Vibratory Greens Rollers

## WB & TS Model Rollers to fit John Deere 2243

Letter	Description	Left Unit	Right Unit	Center Unit
B	Endplate Assembly	37P-18-1		
C	Frame Assembly	30A-22-1	30A-23-1	30A-24-1
E	Motor Mount Shell	30A-31-1 SHELL	30A-38-1 SHELL	30A-38-1 SHELL
F	Shaft Only	30A-09-18		
G	Eccentric Weight 3 1/4"	99P-09-314		
G	Eccentric Weight 5"	99P-09-500		
H	Shaft Bearing	37P-1023		
I	Shaft Snap Ring	37P-1014		
J	Hub Drive End	37P-09-001		
J	Hub Non-Drive End	37P-09-002N		
K	Flanged Bearing Drive End - WB Model *Includes 3 each of Item NN	30A-1016-2		
K	Flanged Bearing Non Drive End - WB Model *Includes 3 each of Item NN	30A-1016-3		
K	Flanged Bearing - TS Model	37P-1016-4		
L	Roller Tube	30A-09-16		
M	Belt	37P-1021		
N	Belt Guard Assembly	30A-14-1	30A-15-1	30A-15-1
P	Pulley	37P-PT003-32		
Q	Long Lift Tube Assembly	30M-JD-101		
QQ	Short Lift Tube Assembly		30M-JD-102	30M-JD-102
RR	Extention Tube for John Deere	30A-JD-300B		
S	Shaft Pulley	37P-1024		
T	Motor Mount Assembly			
	<i>Includes:</i>			
E	Motor Mount Shell	30A-31-1 SHELL	30A-38-1 SHELL	30A-38-1 SHELL
M	19" Belt	37P-1021		
P	Pulley	37P-PT003-32		
U	Pulley Snap Ring	37P-1029		
V	Bearing Snap Ring	37P-1127		
W	Pulley Bearing	37P-1032		
W	Pulley Spacer	30P-J501		
X	Pulley Bearing Housing	30P-J502		
Z	Motor Mount Plate Cover	37P-50-1		
AA	Counterweight Assembly	37P-64-1		
NN	Rubber Shock Mount	30A-RSM		
OO	Hub Spacer	30M-3173		
SS	Anti-Sway Clamp	30A-JD-106		

# True-Surface® Vibratory Greens Rollers

## WB & TS Model Rollers to fit John Deere 2500

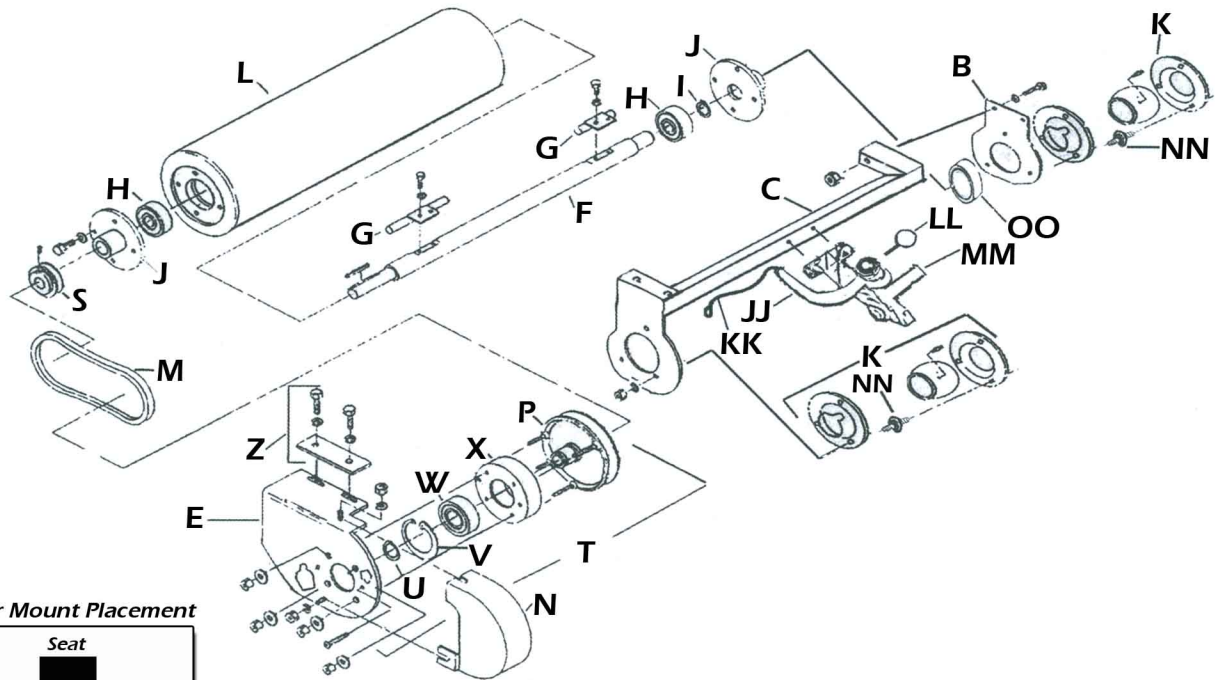

### Motor Mount Placement

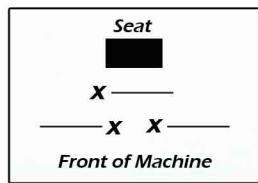

Parts are the same on all units unless otherwise noted.  
 Units are as seated on the operator's seat.  
 Parts include all necessary hardware.

US Patent No. 5,261,231  
 Foreign Patents Passed & Pending

# True-Surface® Vibratory Greens Rollers

## WB & TS Model Rollers to fit John Deere 2500

Letter	Description	Left Unit	Right Unit	Center Unit
B	End Plate Assembly	18-1		
C	Frame Assembly	22-1	23-1	24-1
E	Motor Mount Shell			
F	Shaft Assembly	30A-09-19		
G	Eccentric Weight 3 1/4"	37P-09-314		
G	Eccentric Weight 5"	37P-09-500		
H	Shaft Bearing	37P-1023		
I	Shaft Snap Ring	37P-1014		
J	Hub Assembly Drive End	30A-09-001		
J	Hub Assembly Non-Drive End	30A-09-002N		
K	Flanged Bearing Drive End - WB Model *Includes 3 each of Item NN	30A-1016-2		
K	Flanged Bearing Non Drive End - WB Model *Includes 3 each of Item NN	30A-1016-3		
K	Flanged Bearing - TS Model	37P-1016-4		
L	Roller Assembly	30A-09-1		
M	Belt	37P-1021		
N	Belt Guard Assembly	30A-14-1	30A-15-1	30A-14-1
P	Pulley	37P-PJ003		
S	Shaft Pulley	37P-1024		
T	Quick Motor Mount Assembly			
Includes the following parts:				
E	Motor Mount Shell			
M	Belt	37P-1021		
U	Pulley Snap Ring	37P-1029		
W	Pulley Bearing	37P-1032		
WW	Motor Spacer	30M-2515		
X	Pulley Bearing Housing	30M-T150		
Z	Motor Mount Plate Cover	37P-50-1		
JJ	Leveling Arm Assembly			
KK	Lanyard	30M-2528		
LL	Click pin			
MM	Anti-Sway Bar Assembly			
AA	Counterweight	37P-64-1		
NN	Rubber Shock Mount	30A-RSM		
OO	Hub Spacer	37P-3173		

# True-Surface® Vibratory Greens Rollers

## WB & TS Model Rollers to fit Toro Ransome 2-Bolt

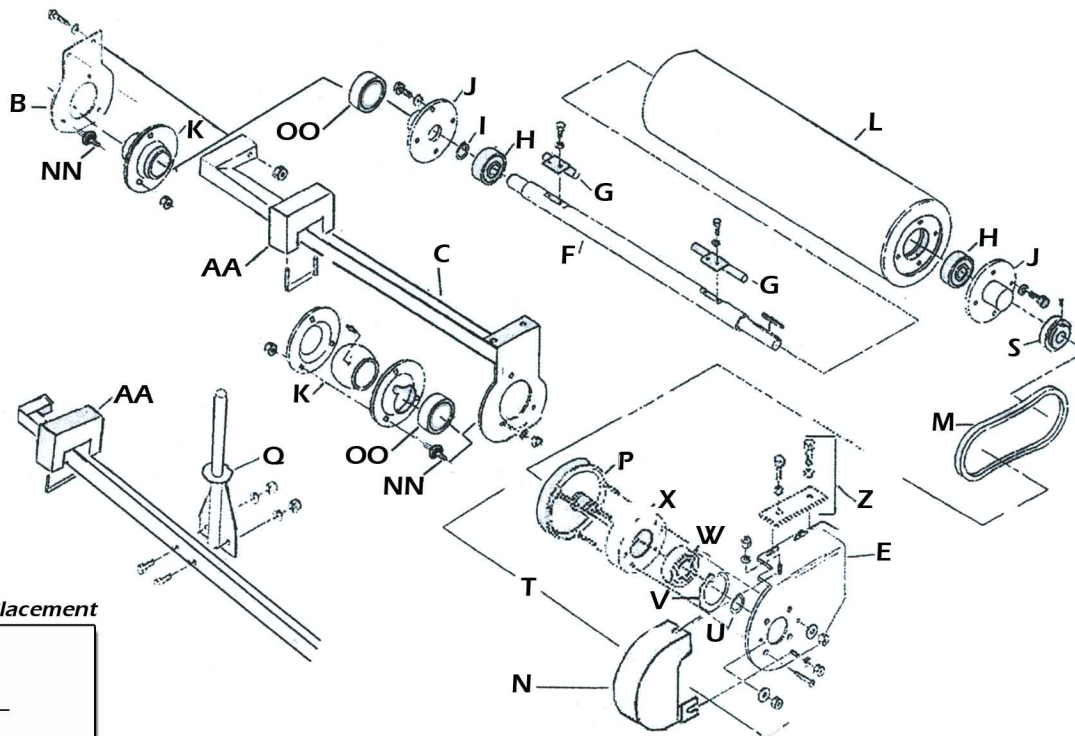

### Motor Mount Placement

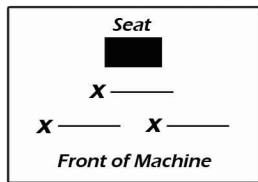

US Patent No. 5,261,231  
Foreign Patents Passed & Pending



## True-Surface® Vibratory Greens Rollers WB & TS Model Rollers to fit Ransome 2-Bolt

Letter	Description	All Units
B	End Plate Assembly	30A-18-1
C	Frame Assembly	
E	Motor Mount Shell Only	30A-3-1 SHELL
F	Shaft Assembly	30A-09-19
G	Eccentric Weight 3 1/4"	37P-09-314
G	Eccentric Weight 5"	37P-09-500
H	Shaft Bearing	37P-1023
I	Shaft Snap Ring	37P-1014
J	Hub Assembly Drive End	30A-09-001
J	Hub Assembly Non-Drive End	30A-09-002N
K	Flanged Bearing Drive End - WB Mode *Includes 3 each of Item NN	30A-1016-2
K	Flanged Bearing Non Drive End - WB Model *Includes 3 each of Item NN	30A-1016-3
K	Flanged Bearing - TS Model	30A-1016-4
L	Roller Assembly	30A-09-1
M	19" Belt	37P-1021
N	Belt Guard Assembly	30A-14-1
P	5" Pulley	37P-PJ003
Q	Lift Pin	37P-17-1
S	Shaft Pulley	37P-1024
T	Quick Motor Mount Assembly	
Includes the following parts:		
E	Motor Mount Shell	30A-3-1 SHELL
M	Belt	37P-1021
P	5" Pulley	37P-PJ003
U	Pulley Snap Ring	37P-1029
V	Bearing Snap Ring	37P-1127
W	Pulley Bearing	37P-1032
X	Pulley Bearing Housing	30M-T150
Z	Motor Mount Plate Cover	37P-50-1
AA	Counterweight	37P-64-1
NN	Rubber Shock Mount	30A-RSM
OO	Hub Spacer	37P-3173

# True-Surface® Vibratory Greens Rollers

## WB & TS Model Rollers to fit Toro Ransome 4-Bolt

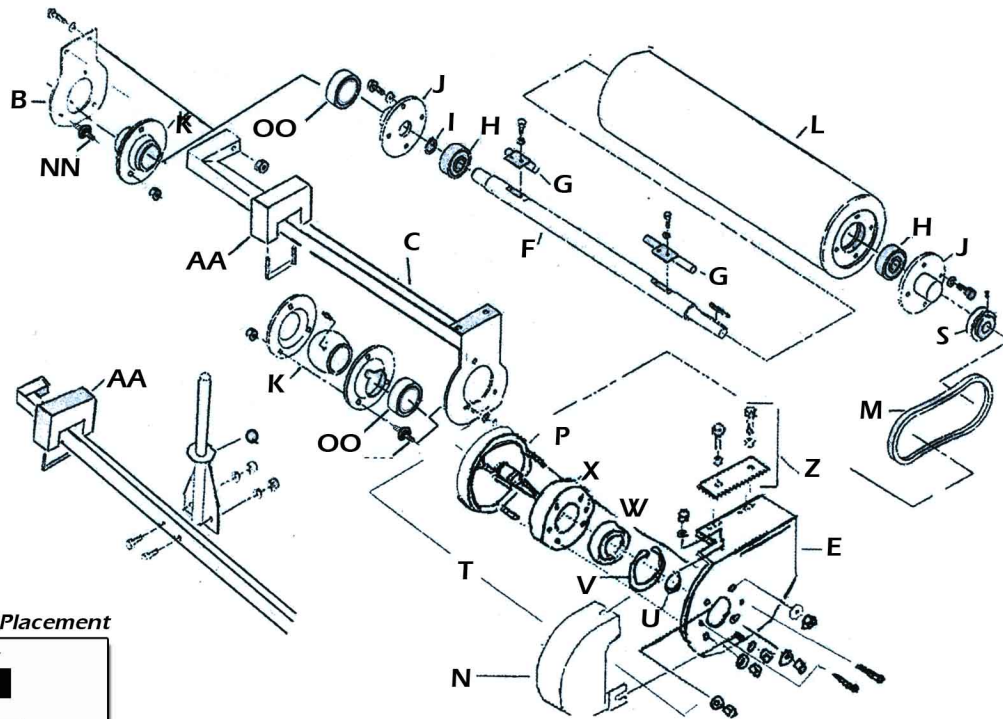

**Motor Mount Placement**

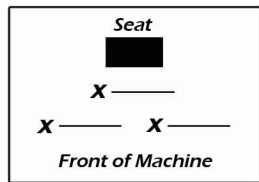

US Patent No. 5,261,231  
Foreign Patents Passed & Pending

## True-Surface® Vibratory Greens Rollers WB & TS Model Rollers to fit Ransome 4-Bolt

<b>Letter</b>	<b>Description</b>	<b>All Units</b>
B	End Plate Assembly	30A-18-1
C	Frame Assembly	
E	Motor Mount Shell Only	30A-31-1 SHELL
F	Shaft Assembly	30A-09-19
G	Eccentric Weight 3 1/4"	37P-09-314
G	Eccentric Weight 5"	37P-09-500
H	Shaft Bearing	37P-1023
I	Shaft Snap Ring	37P-1014
J	Hub Assembly Drive End	30A-09-001
J	Hub Assembly Non-Drive End	30A-09-002N
K	Flanged Bearing Drive End - WB Model *Includes 3 each of Item NN	30A-1016-2
K	Flanged Bearing Non Drive End - WB Model *Includes 3 each of Item NN	30A-1016-3
K	Flanged Bearing - TS Model	30A-1016-4
L	Roller Assembly	30A-09-1
M	19" Belt	37P-1021
N	Belt Guard Assembly	30A-14-1
P	5" Pulley	37P-PJ003
Q	Lift Pin	37P-17-1
S	Shaft Pulley	37P-1024
T	Quick Motor Mount Assembly	30A-31-1
Includes the following parts:		
E	Motor Mount Shell	
M	19" Belt	37P-1021
P	5" Pulley	37P-PJ003
U	Pulley Snap Ring	37P-1029
V	Bearing Snap Ring	37P-1127
W	Pulley Bearing	37P-1032
X	Pulley Bearing Housing	30M-T150
Z	Motor Mount Plate Cover	37P-50-1
AA	Counterweight	37P-64-1
NN	Rubber Shock Mount	30A-RSM
OO	Hub Spacer	37P-3173